

SHH

SPECIFICATION

Bore [mm]	MODEL	Output [kw]	Head [m]	Capacity	A	H	L	Weight
100	SHH 100 - 22 2T	22	60	1.0	470	1350	300	500
150	SHH 150 - 22 2T	22	35	2.0	470	1350	300	500
	SHH 150 - 30 2T	30	60	1.4	470	1350	300	530
	SHH 150 - 37 2T	37	60	2.0	620	1545	350	770
	SHH 150 - 45 2T	45	60	2.5	620	1545	350	800
	SHH 150 - 55 2T	55	90	2.0	620	1545	350	820
200	SHH 200 - 30 2T	30	35	2.7	470	1350	300	530
	SHH 200 - 37 2T	37	35	3.6	620	1545	350	770
	SHH 200 - 45 2T	45	35	4.5	620	1545	350	800
	SHH 200 - 55 2T	55	50	4.0	620	1545	350	820
	SHH 200 - 75 2T	75	60	4.5	620	1545	350	820

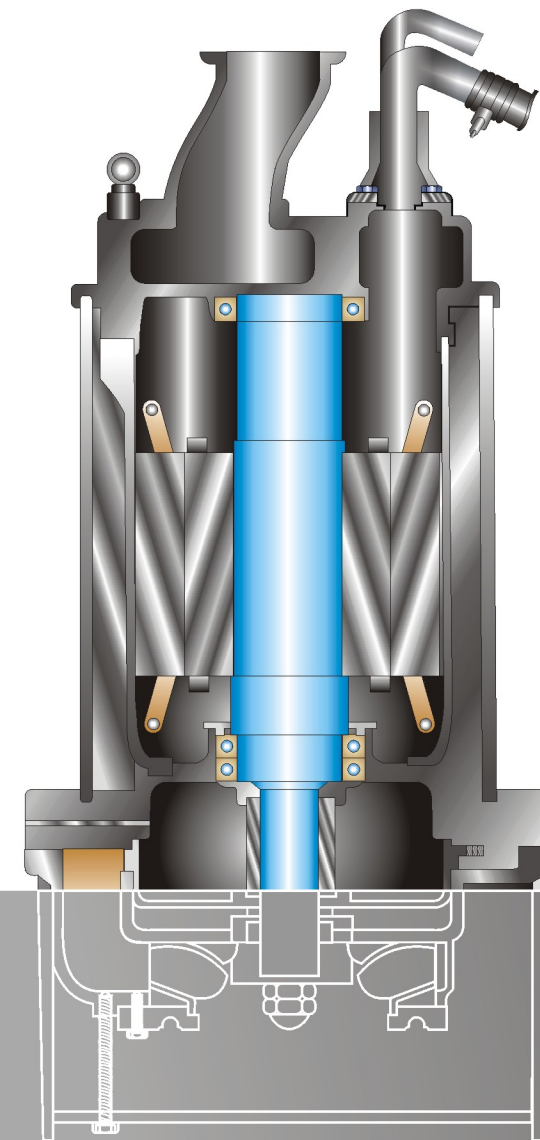

Submersible High Head Dewatering Pump



PT TORISHIMA GUNA ENGINEERING

HEAD OFFICE : Jl. Rawa Sumur Timur No. 1 Pulugadung Industrial Estate,
Jakarta 13930 - Indonesia. Phone: +62 21 460 3962, Fax: +62 21 460 3937
Email : tge-info@torishima-guna.co.id

TURBOMACHINERY WORKSHOP : Jl. Selayar II Blok H-12, Kawasan Industri MM2100
Telajung, Cikarang Barat Bekasi 17845, West Java - Indonesia.
Phone: +62 21 2957 6955, Fax: +62 21 2957 6956

@ tge.id | www.torishimaguna.com





SHH

HIGH HEAD DEWATERING PUMP FOR CIVIL ENGINEERING SITE

Submersible close impeller with single or two stage design

MOTOR

- 2 Pole
- Insulation Class : F
- Voltage :
3 Phase/220V/380V/440V
- 3000 rpm
- Starting Methods : Star Delta
- Standard Power : 22 kW ~ 110 kW
Other motor ratings available upon request

PUMP

- Impeller : Enclosed type
- Material :
 - Impeller : FC 200 / BC 6
 - Casing : FC200 / SCS 13
 - Suction Cover : FC 200 / SCS 13
 - Shaft : SUS410 / SUS 304
- Other material are available upon request
- Connecting Method :
 - Flange Coupling / Hose Coupling

APPLICATION

- High Head
- Drainage at mine
- Long-distance pressuring dewatering/drainage at golf link & reservoir
- Dewatering / drainage at road, harbor, dam construction site

FEATURES

- Applicable to higher head than other dewatering pumps with 2 poles and enclosed impeller
- Maximize cooling effect of motor with water jacket around motor
- Including motor protector
- Perfect watertight with double mechanical seal



SECTIONAL DRAWING

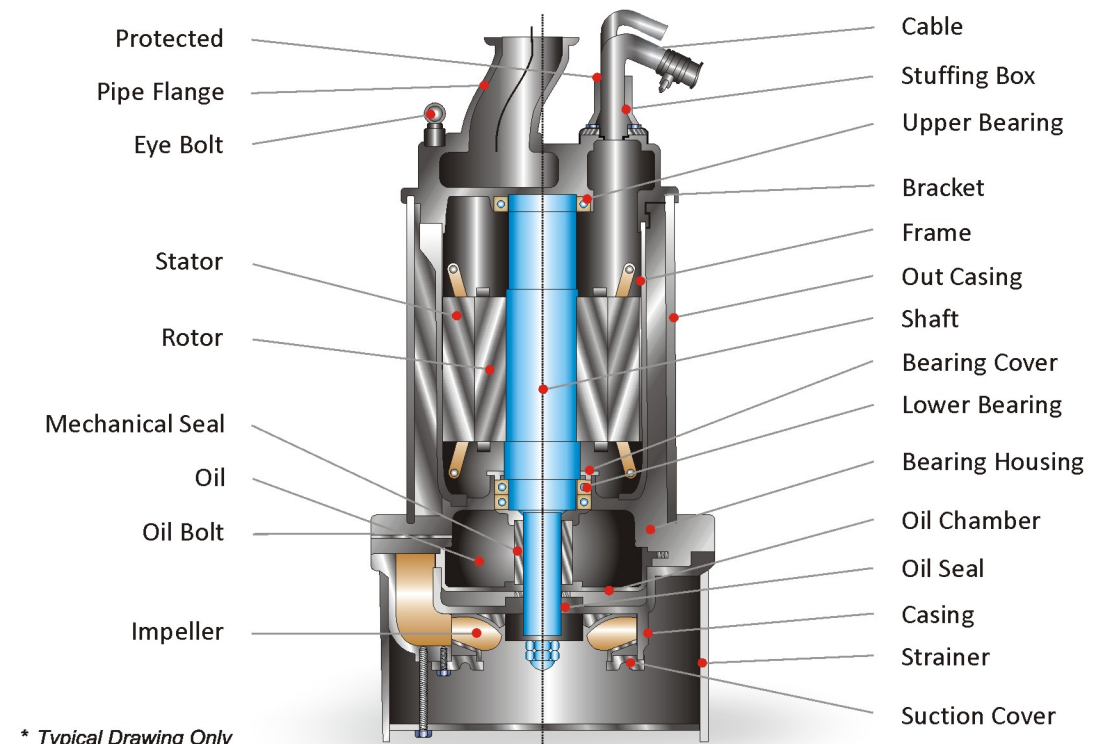

* Typical Drawing Only

PERFORMANCE CURVE

