

# TG KSM

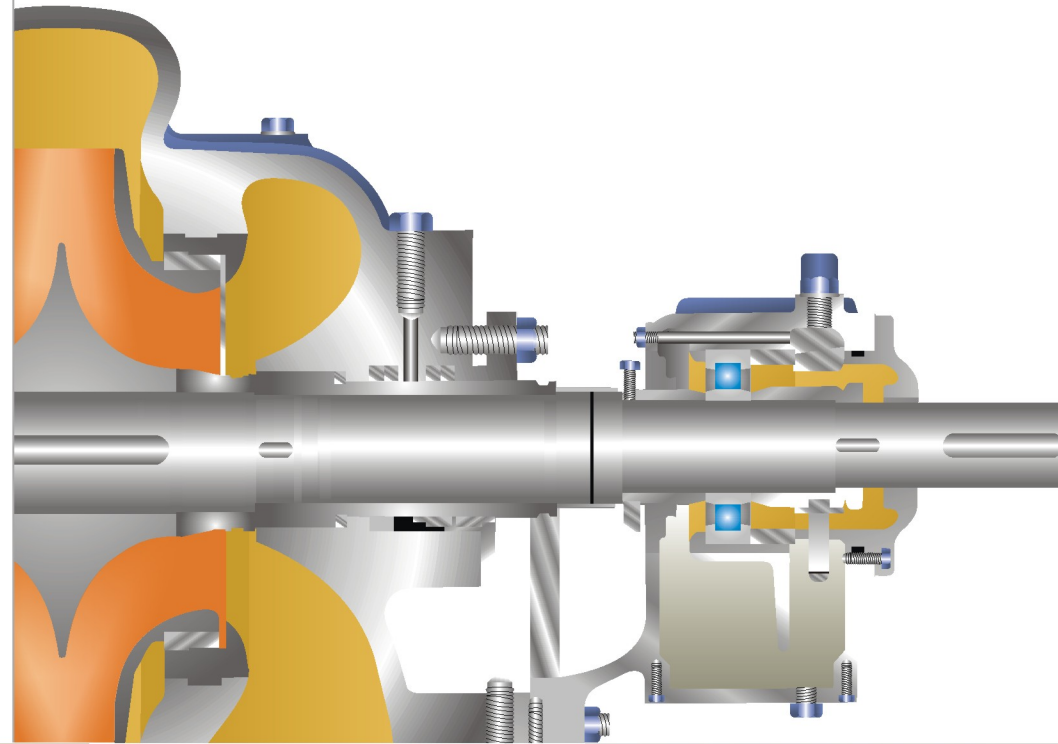
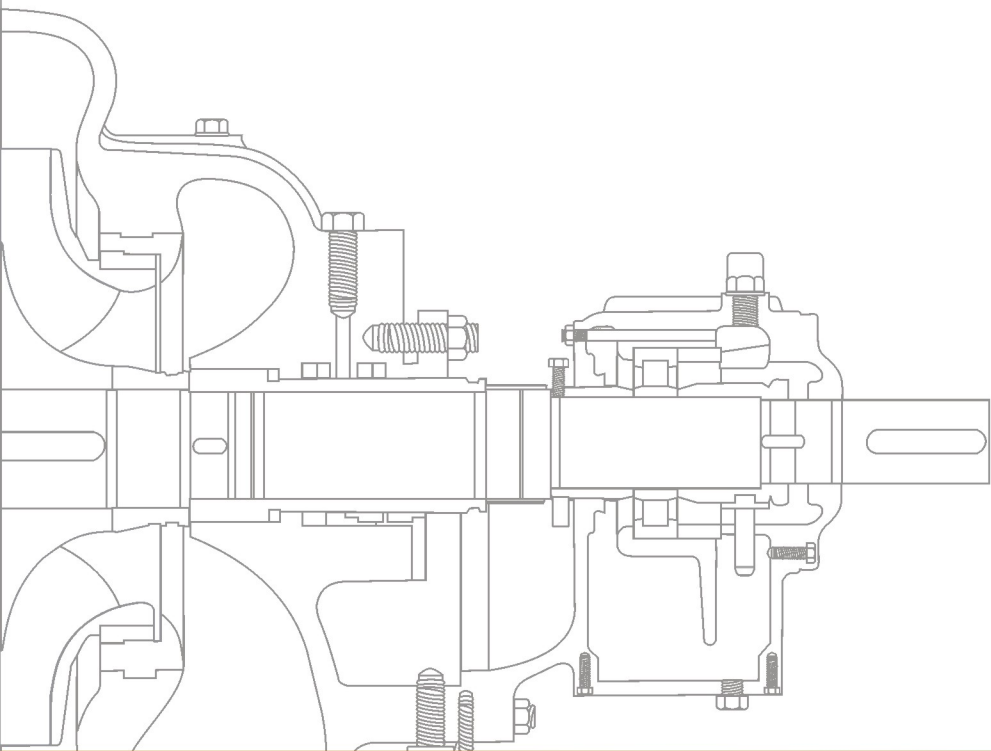

## PT TORISHIMA GUNA ENGINEERING

HEAD OFFICE : Jl. Rawa Sumur Timur No. 1 Pulugadung Industrial Estate,  
Jakarta 13930 - Indonesia. Phone: +62 21 460 3963, Fax: +62 21 460 3937  
Email : tge-info@torishima-guna.co.id

TURBOMACHINERY WORKSHOP : Jl. Selayar II Blok H-12, Kawasan Industri MM2100  
Telajung, Cikarang Barat Bekasi 17845, West Java - Indonesia.  
Phone: +62 21 2957 6955, Fax: +62 21 2957 6956

@ tge.id | www.torishimaguna.com

Axially Split Between  
Bearing Pump  
API 610 10<sup>th</sup> Ed  
BB1 Type



## GENERAL

TG KSM series are single or two stage, double suction centrifugal pump designed in accordance with API 610 10<sup>th</sup> Ed ( BB1 Type ). Main application fields of this pump series are oil refinery, chemical, and petrochemical plants.

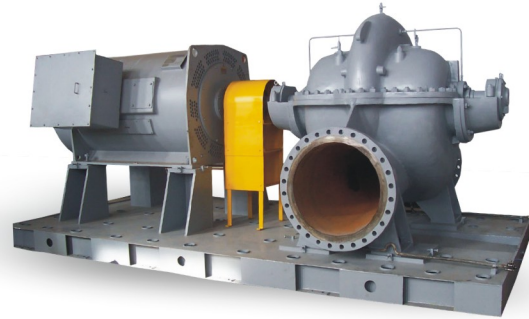

## OPERATING RANGE

Capacity	Q	up to 12,000 m <sup>3</sup> /hr	( 53,000 usgpm )
Total head	H	up to 440 m	( 1,440 feet )
Temperature	T	- 20 up to + 200 °C	( - 4 to 390 °F )
Discharge pressure	P	0.4 up to 6.4 MPa	( 58 to 925 psi )
Nozzle size	DN	125 to 800 mm	( 5 to 32 inch )

## NOMENCLATURE

TG KSM	:	Double suction axial split case pump
401	:	Discharge nozzle, mm
500	:	Impeller nominal diameter, mm



## DIRECTION OF ROTATION

Clock-wise / CW viewed from the drive end.

## CONSTRUCTION

Casing	:	Axial split case type, enable the pump to be carried at maintenance and overhaul without disturbing the pipeline and driver.
Impeller	:	Double suction type minimize the axial thrust. Close impeller design gives high efficiency performance and smooth operation.
Shaft	:	Heavy duty design ; can be overturn to allow the pump to be driven from other side.
Sealing Chamber	:	Designed for either gland packing or mechanical seal execution.

## SELECTION CHART

### 50 Hz

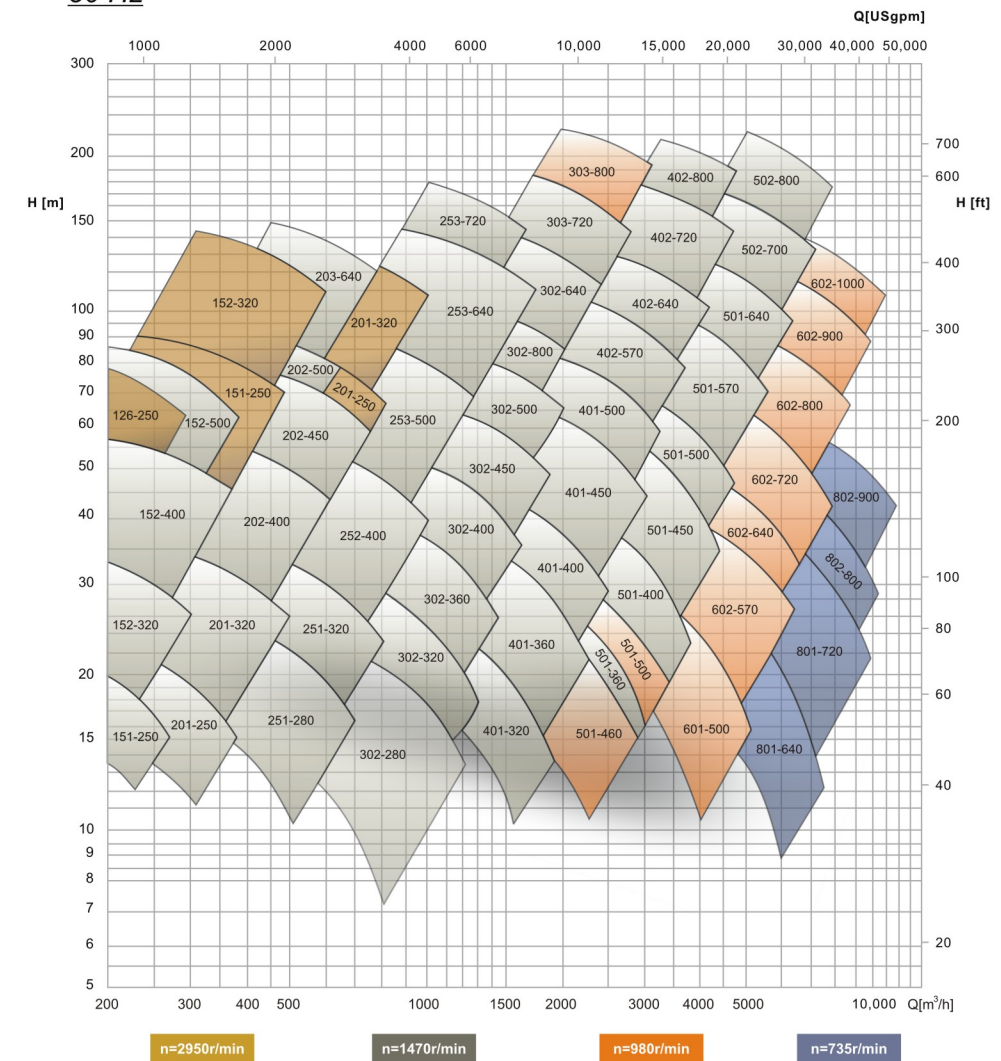

\* Performance charts at other different speed are also available.

## SECTIONAL DRAWING

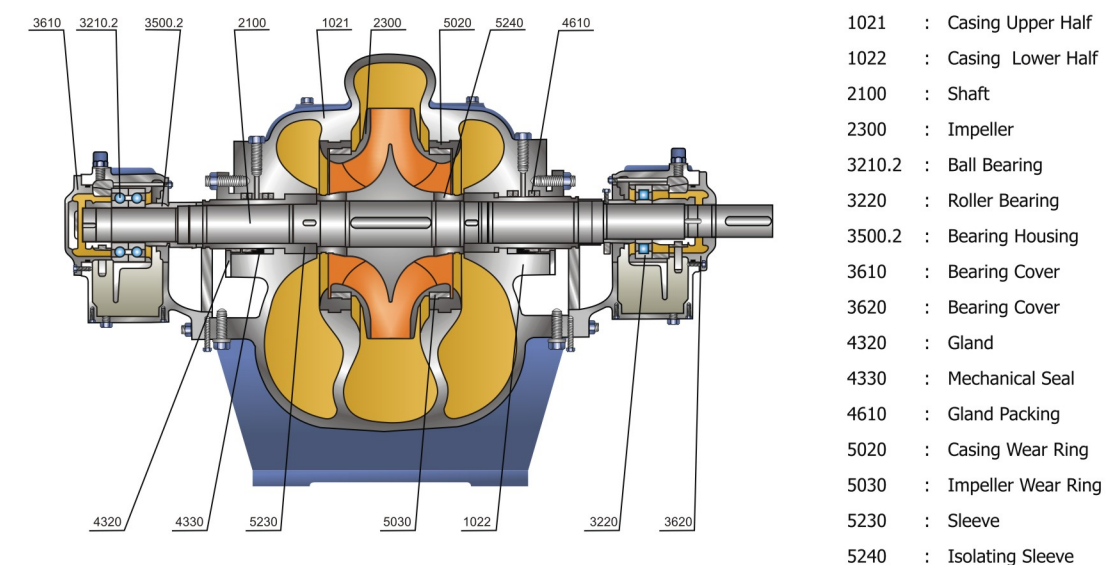

\* Typical drawing only